

BW LSOH Gland Kit

420LSF Series



The BW Gland kit is an industrial indoor cable gland for rapid termination of LSOH cables.

Features and benefits:

- Indoor type for LSOH SWA cable
- Brass Indoor gland and LSOH accessories
- For galvanized-steel single-wire armour, plastic or rubber LSOH sheathed cables
- For use in dry dust free situations
- Provides mechanical cable retention and electrical continuity via armour locking mechanism

Kit comprises

BW Gland
Brass Earth Tag
Brass Locknut
LSOH Shroud
(2 per kit up to and including 25mm size)



Technical Information:

- Suitable for use with all Steel Wire Armoured Cables inc: BS 6724
- CuZn39Pb3 brass alloy used for guaranteed strength and performance
- Complies with BS 6121-1:2005
- Service temperature rang -20°C to +90°C
- Complies with LU Standard 1-085 for installation in all sub-surface locations
- LUL APR Product ID 1968

Specifications

Gland Kit Reference			Cable Dimensions mm			Gland Dimensions mm				
Design Reference	Size	Qty per Kit	Under Armour ϕ (A)		Armour Wire ϕ	Entry Thread (D)	Thread Length (E)	Protrusion Length (F)	Hexagon	
			Max						A/F (G)	A/C (H)
420LSF-52	20s	2	11.6		0.9	M20x1.5	10	24	22	24.9
420LSF-53	20	2	13.9		0.9/1.25	M20x1.5	10	25	27	30.5
420LSF-55	25	2	19.9		1.25/1.6	M25x1.5	10	26	32.9	36.8
420LSF-56	32	1	26.2		1.6/2.0	M32x1.5	10	28	42.4	47.8
420LSF-57	40	1	32.1		1.6/2.0	M40x1.5	15	25	50	57
420LSF-59	50	1	44		2.0/2.5	M50x1.5	15	36	70.1	77.2
420LSF-61	63	1	55.9		2.5	M63x1.6	15	30	80	87.4
420LSF-62	75s	1	61.9		2.5	M75sx1.6	15	40	85	95
420LSF-63	75	1	67.9		2.5	M75x1.6	15	40	98.8	109.2

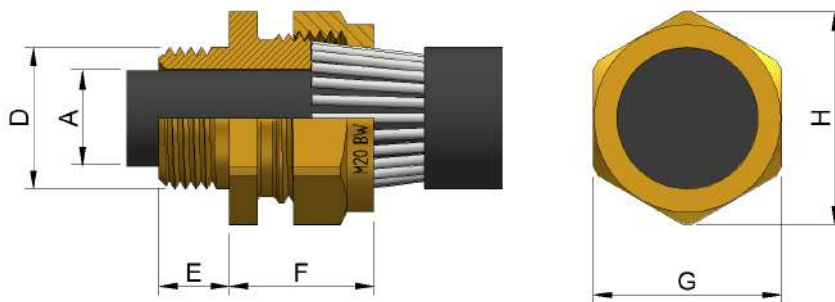

Prysmian Cables & Systems Limited,
Oak Road, Wrexham Industrial Estate, Wrexham, LL13 9PH, UK

Commercial Enquiries,
Sales Office Tel: 0845 767 8345,
International Sales Office Tel: +44 2380 295481

www.biconcomponents.co.uk

